

PRODUCT INFORMATION

COMMERCIAL/INDUSTRIAL

STANDARD

PUNCHING PATTERNS FOR 8" X 5" X 2 3/4" EAVE STRUTS

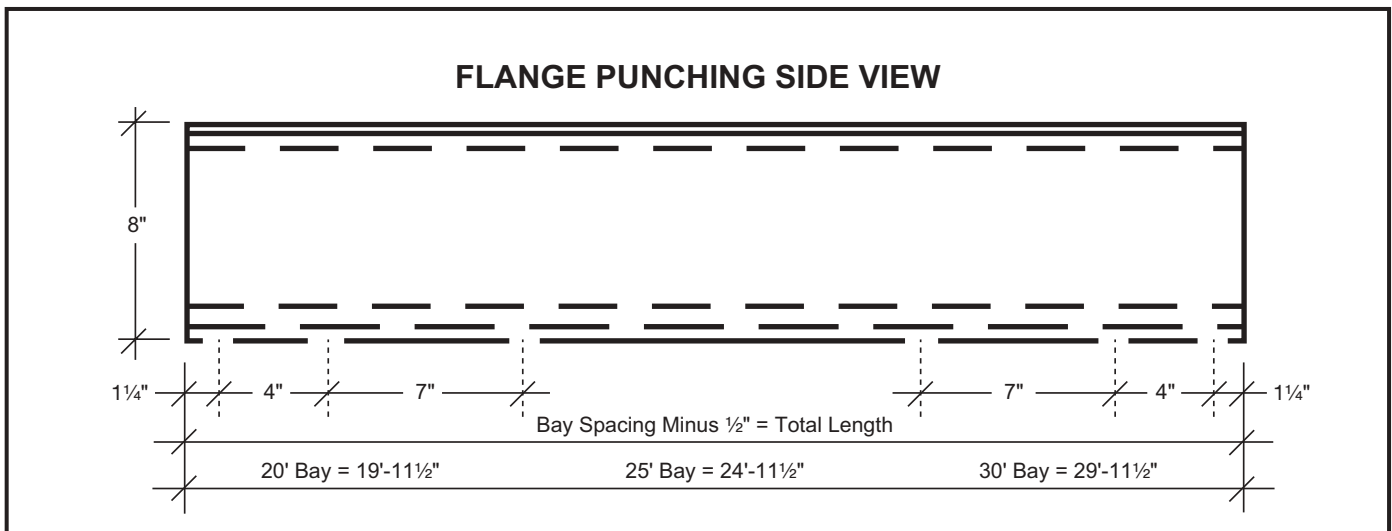
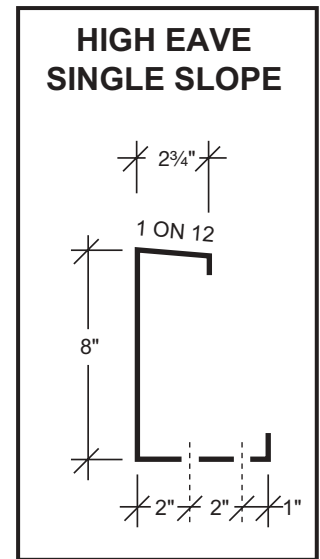
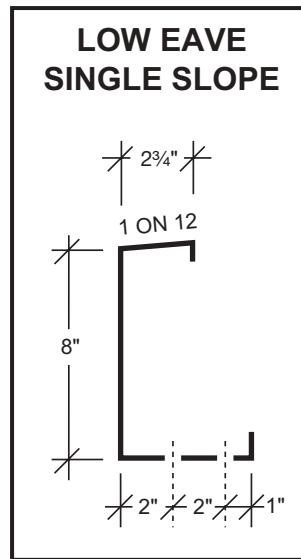
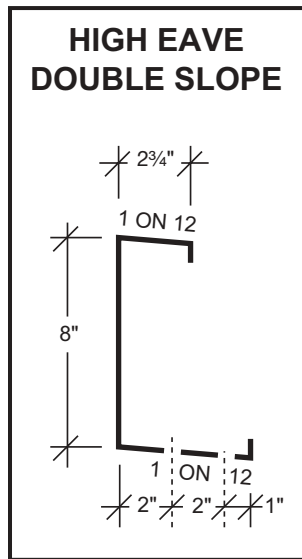
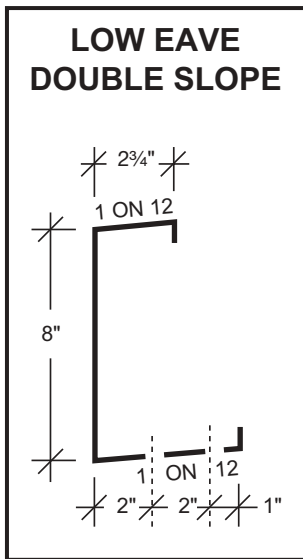

NOTES:

1. All holes are 1 3/16".
2. Eave strut is 12 or 14 gauge.

COMMERCIAL/INDUSTRIAL

PRODUCT INFORMATION

OPTIONAL
PUNCHING PATTERNS FOR 8" X 5" X 2 3/4" EAVE STRUTS

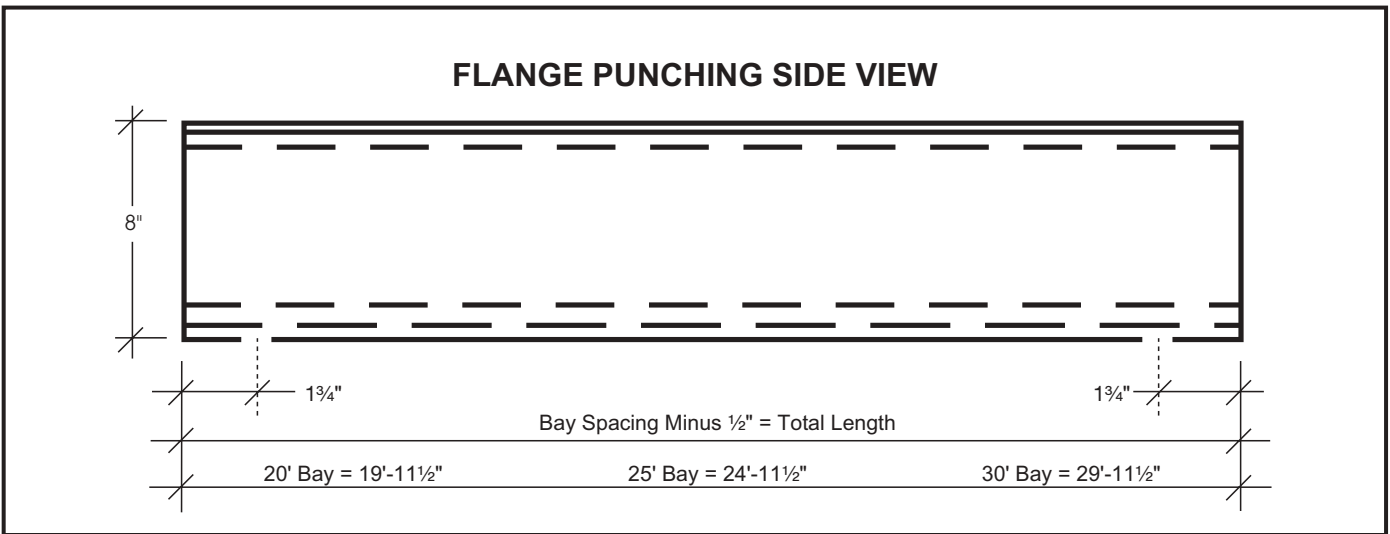
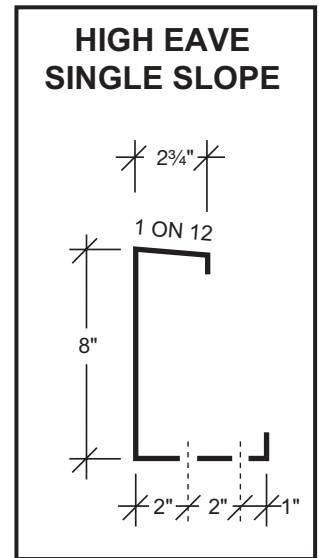
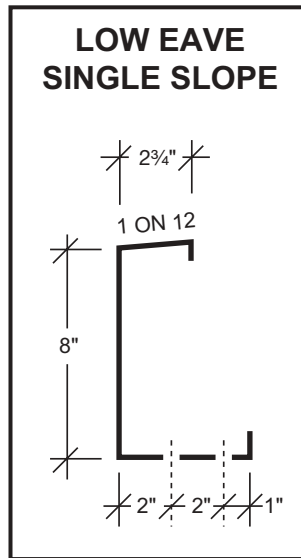
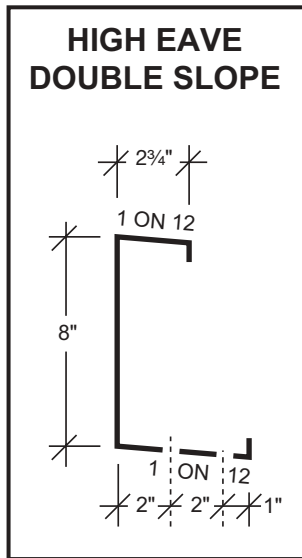
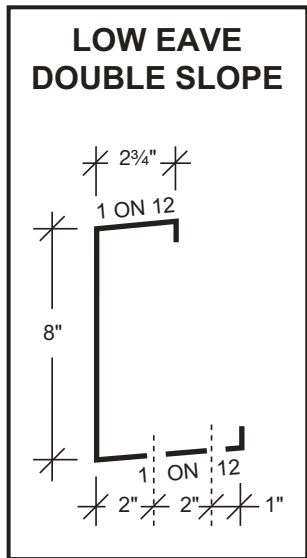

NOTES:

1. All holes are 5/8" diameter.
2. Eave strut is 12 or 14 gauge.